

# Aluet S/100

Diseño / Design:  
Emiliana Design / 2023

Tipología: Suspensión  
Typology: Pendant lamp

Ambiente: Interior  
Environment: Indoor

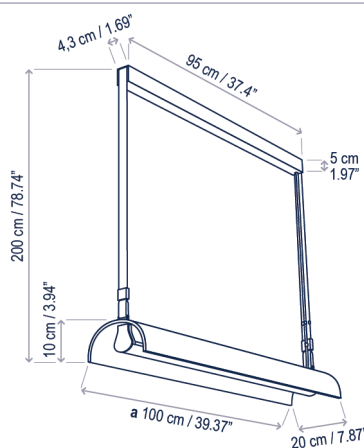

## Descripción técnica / Technical description:

### Iluminación indirecta / Indirect lighting

Peso Neto: 6,3 kg  
Net Weight: 6,3 kg

1 Caja/Box | 26 x 109 x 25 cm | 0,0709 m<sup>3</sup>  
Peso bruto / Gross Weight: 7,75 kg

### Iluminación directa e indirecta / Direct and indirect lighting

Peso Neto: 6,75 kg  
Net Weight: 6,75 kg

1 Caja/Box | 26 x 109 x 25 cm | 0,0709 m<sup>3</sup>  
Peso bruto / Gross Weight: 8,2 kg

Materiales: Aluminio, Acero, Madera, Algodón  
Materials: Aluminum, Steel, Wood, Cotton

Al tratarse de madera natural, los tonos de las pantallas pueden no ser los mismos en todos los casos.  
Made with natural wood. Shades may have variations in tone.

Opciones Dali/1-10V: consultar  
Dali/1-10V options: consult

Personalizable: consultar  
Customizable: consult

Certificaciones  
Certifications

## Descripción lámpara iluminación indirecta / Indirect lighting lamp description:

230V 50HZ | IP-20 | TRIAC | 34,56 W LED / CRI: 90 / 2700K / 4200 lm | fuente luz indirecta / indirect light source |

Ref	Acabados / Finishing	Ean13
13202215322	Regulable Triac Beige-Madera Fresno Dimmable Triac Beige-Ash Wood	8435493740638

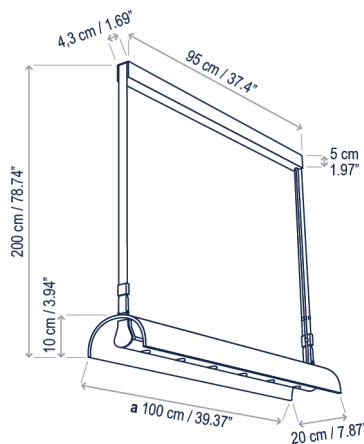

## Descripción lámpara iluminación directa e indirecta / Direct and indirect lighting lamp description:

230V 50HZ | IP-20 | TRIAC | 21,6 W LED / CRI: 90 / 2700K / 2800 lm | fuente luz indirecta / indirect light source |   
 19,2 W LED / CRI: 90 / 2700K / 2232 lm | fuente luz directa / direct light source |

Ref	Acabados / Finishing	Ean13
13201215322	Regulable Triac Beige-Madera Fresno Dimmable Triac Beige-Ash Wood	8435493740591

**bover**  
barcelona lights

Avda. Catalunya 173  
Poligon Ind. Sud  
08440 Cardedeu  
Barcelona, Spain

T. +34 938 713 152  
F. +34 938 462 089  
info@bover.es  
www.bover.es

## Familia / Family: Aluet

